



HYDRAULIC MEGASTORE

Serving the Hydraulics Industry Worldwide



Return Filters

D 043

- Tank top mounting / in-line mounting
- Connection G1/2
- Nominal flow rate up to 45 l/min

Description

Application

In the return line circuits of hydraulic systems.

Performance features

Protection

against wear: By means of filter elements that, in full-flow filtration, meet even the highest demands regarding cleanliness classes.

Protection against malfunction: By means of full-flow filtration in the system return, the pumps above all are protected from dirt particles remaining in the system after assembly, repairs, or which are generated by wear or enter the system from outside.

Special features

By-pass valve: The location close to the inlet port prevents dirt particles retained by the filter element from entering into the clean oil side.

Dirt collecting bowl: Prevents back-flushing of collected dirt particles during element replacement.

Connection: A female thread in the bowl outlet makes in-line mounting possible.

Filter elements

Flow direction from outside to centre. The star-shaped pleating of the filter material results in:

- large filter surfaces
- low pressure drop
- high dirt-holding capacities
- long service life

In filters with a magnetic system, the ferromagnetic particles in the fluid pass first through a strong magnetic field and are separated.

Ventilating Filter

Ventilation of the reservoir by an integral star-shaped pleated filter element:

- removable (replace annually!)
- splash-proof
- fineness 2 µm

Some versions are also available with galvanized steel wool.

Filter maintenance

By using a clogging indicator the correct moment for maintenance is stated and guarantees the optimum utilization of the filter life.

Materials

Screw-on cap:	Polyamide, GF reinforced
Housing:	Aluminium alloy
Seals:	NBR (FPM on request)
Filter media:	EXAPOR [®] MAX 2 – inorganic microfibre web Paper – cellulose web, impregnated with resin Stainless steel wire mesh (1.4301) with mesh size 40 and 60 µm.

Accessories

An optional oil separator (Part No. D 023.1702) prevents oil splashing through the ventilating filter at mobile applications. Electrical and optical clogging indicators are available on request. Dimensions and technical data see catalogue sheet 60.20.

Characteristics

Nominal flow rate

Up to 45 l/min (see Selection Chart, column 2)

The nominal flow rates indicated by ARGO-HYTOS are based on the following features:

- closed by-pass valve at $v \leq 200 \text{ mm}^2/\text{s}$
- element service life > 1.000 operating hours at an average fluid contamination of 0,07 g per l/min flow volume
- flow velocity in the connection lines $\leq 4,5 \text{ m/s}$

Connection

Threaded ports according to ISO 228 or DIN 13.

Sizes see Selection Chart, column 6 (other port threads on request)

Filter fineness

10 µm(c) ... 60 µm(c)

β-values according to ISO 16889

(see Selection Chart, column 4 and diagram Dx)

Dirt-holding capacity

Values in g test dust ISO MTD according to ISO 16889

(see Selection Chart, column 5)

Hydraulic fluids

Mineral oil and biodegradable fluids

(HEES and HETG, see info-sheet 00.20)

With high filling conditions we recommend an electrical conductivity $\geq 500 \text{ pS/m}$ at 20°C.

Temperature range

-30°C ... +100°C (temporary -40°C ... +120°C)

Viscosity at nominal flow rate

- at operating temperature: $v < 60 \text{ mm}^2/\text{s}$
- as starting viscosity: $v_{\text{max}} = 1.200 \text{ mm}^2/\text{s}$
- at initial operation: The recommended starting viscosity can be read from the diagram D (pressure drop as a function of the kinematic viscosity) as follows: Find the 70 % Δp of the cracking pressure of the by-pass valve on the vertical axis. Draw a horizontal line so that it intersects the Δp curve at a point. Read this point on the horizontal axis for the viscosity.

Operating pressure

Max. 16 bar

Mounting position

Preferably vertical, outlet downwards

Diagrams

Δp -curves for complete filters in Selection Chart, column 3

D1

Pressure drop as a function of the **flow volume**
at $v = 35 \text{ mm}^2/\text{s}$ ($0 = \text{casing empty}$)

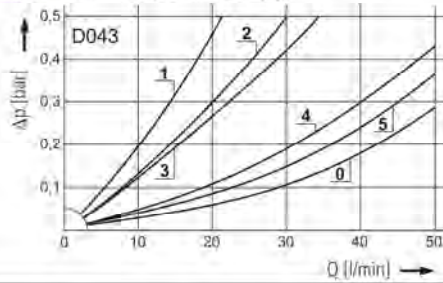

Pressure drop as a function of the **kinematic viscosity**
at nominal flow

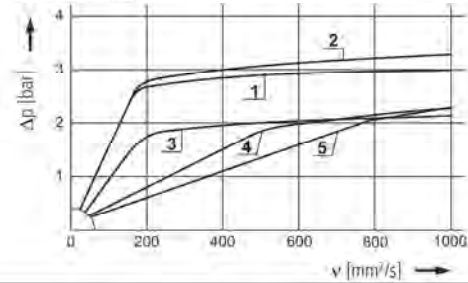

Filter fineness curves in Selection Chart, column 4

Dx

Filtration ratio β as a function of particle size x obtained by the
Multi-Pass-Test according to ISO 16889

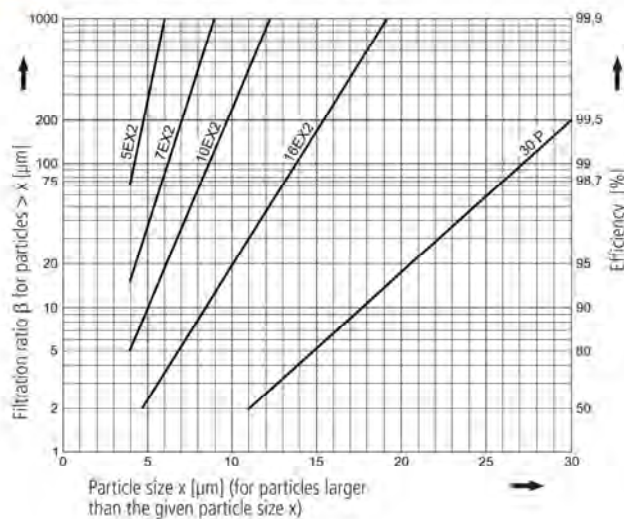

The abbreviations represent the following β -values resp. finenesses:

For EXAPOR®MAX 2- and Paper elements:

- 5EX2** = $\beta_{5(\mu\text{m})} = 200$ EXAPOR®MAX 2
- 7EX2** = $\beta_{7(\mu\text{m})} = 200$ EXAPOR®MAX 2
- 10EX2** = $\beta_{10(\mu\text{m})} = 200$ EXAPOR®MAX 2
- 16EX2** = $\beta_{16(\mu\text{m})} = 200$ EXAPOR®MAX 2
- 30P** = $\beta_{30(\mu\text{m})} = 200$ Paper

Based on the structure of the filter media of the 30P paper elements, deviations from the printed curves are quite probable.

For screen elements:

- 40S** = screen material with mesh size 40 μm
- 60S** = screen material with mesh size 60 μm
- 100S** = screen material with mesh size 100 μm

Tolerances for mesh size according to DIN 4189

For ventilating filter elements:

- 2 CL** = 99,5 % filter efficiency for particles of size 2 μm

For special applications, finenesses differing from these curves are also available by using special composed filter material.

Selection Chart

	Part No.	Nominal flow rate Pressure drop see diagram D/curve no.	Filter fineness see Diagram Dx	Dirt-holding capacity Filter surface in (l)	Connection A/B	Cracking pressure of by-pass Symbol	Replacement filter element Part No.	Weight	Wet air filter	Remarks	
	l/min			g	bar			kg			
1	2	3	4	5	6	7	8	9	10	11	12
D 043-106	23	D1/1	10EX2	6,1	G½	2,5	1	V3.0510-56	0,4	-	-
D 043-88	35	D1/2	16EX2	6,1	G½	2,5	1	V3.0510-58	0,4	-	-
D 043-73	30	D1/3	30P	4,0	G½	1,5	1	P3.0510-51	0,4	-	-
D 043-05	40	D1/4	40S	(220 cm²)	G½	1,5	4	S3.0508-55	0,47	•	with magnetic system
D 043-10	45	D1/5	60S	(220 cm²)	G½	1,5	4	S3.0508-50	0,47	•	with magnetic system

All filters are delivered with a plugged clogging indicator connection M 12 x 1,5.
As clogging indicators either manometers or electrical pressure switches can be used.

For the appropriate clogging indicator see catalogue sheet 60.20.

Remarks:

- The switching pressure of the electrical pressure switch has always to be lower than the cracking pressure of the by-pass valve (see Selection Chart, column 7).
- The clogging indicators are optionally available and will then be loosely provided.
- The filters listed in this chart are standard filters. If modifications are required, e.g. different filter finenesses or with ventilating filter, we kindly ask for your request.

Dimensions

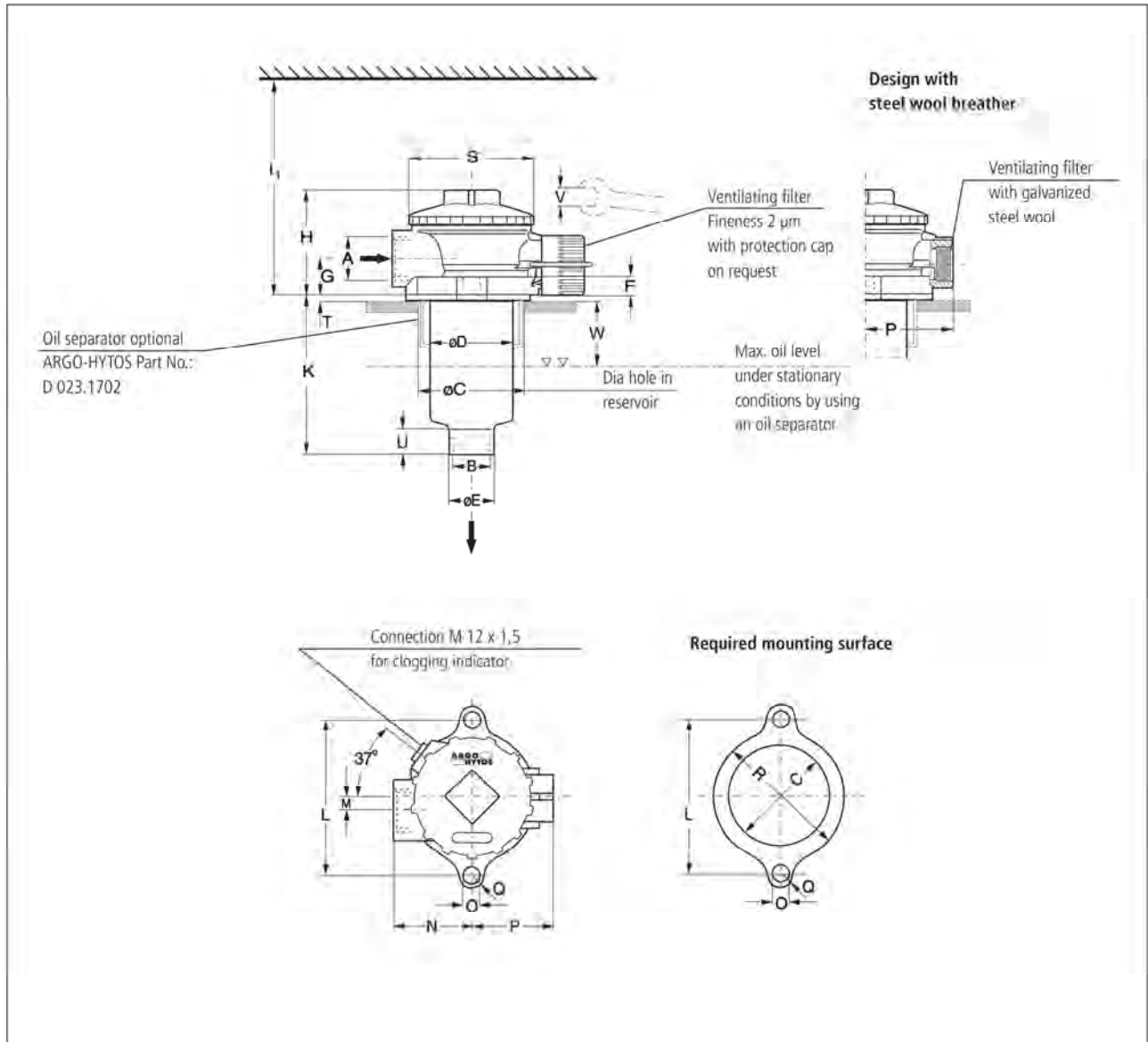

Measurements

Type	A	B	C min./max.	D	E	F	G	H	I	K	L	M	N	O	P	Q	R	S	T	U
D 043	G½	G½	60/63	52	27,8	11,5	24	67	150	87,5	88	9	50	11	45	9,5	75,5	73,5	2	18
Type	V	W																		
D 043	27	42																		

Symbols

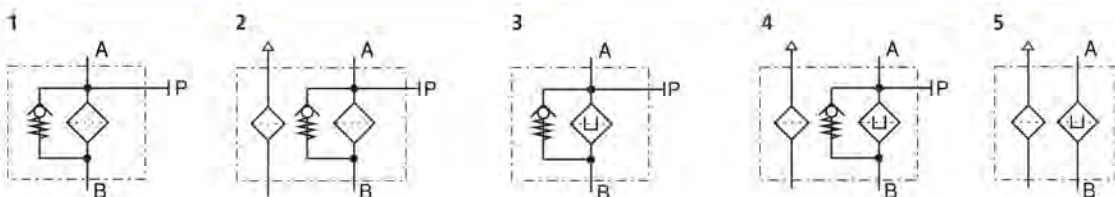

Spare Parts

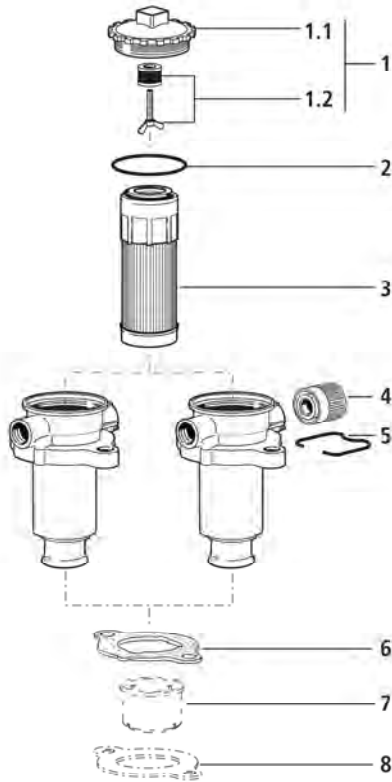

Pos.	Designation	Part No.
1	Screw-on cap (with Pos. 2) for D 043 with magnetic system	D 043.1210
1.1	Screw-on cap	D 043.2202
1.2	Magnetic system	M0.2501-00
2	Flat gasket	N031.0562
3	Filter element	see Chart / col. 9
4	Ventilating filter (with Pos. 5)	L1.0406-01K7
5	Clip	N026.0253
6	Flat gasket	D 023.0704
7	Oil separator (with Pos. 8)	D 023.1702
8	Flat gasket for D 043 with oil separator	D 023.0718

The functions of the complete filters as well as the outstanding features of the filter elements assured by ARGO-HYTOS can only be guaranteed if original ARGO-HYTOS spare parts are used.

Quality Assurance

Quality management according to DIN EN ISO 9001

To ensure constant quality in production and operation, ARGO-HYTOS filter elements undergo strict controls and tests according to the following ISO standards:

- ISO 2941 Verification of collapse/burst pressure rating
- ISO 2942 Verification of fabrication integrity (Bubble Point Test)
- ISO 2943 Verification of material compatibility with fluids

- ISO 3968 Evaluation of pressure drop versus flow characteristics
- ISO 16889 Multi-Pass-Test (evaluation of filter fineness and dirt-holding capacity)
- ISO 23181 Determination of resistance to flow fatigue using high viscosity fluid

Various quality controls during the production process guarantee the leakfree function and solidity of our filters.



**HYDRAULIC
MEGASTORE**

www.hydraulicmegastore.com
Tel: 0800 622 6192

Datasheet Reference:
HM 000-169