

Column level indicators with transparent protection for glycol-based solutions

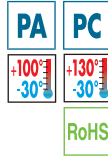

• Assembly ends

Glass-fibre reinforced polyamide based (PA) technopolymer, black colour.

• Support

Aluminium in natural colour.

• Level column window

Transparent tube in Pyrex[®] glass, also suitable for use with glycol-based solutions.

Maximum fluid level visibility even from side positions

• Transparent front protection (against accidental shocks)

Polycarbonate (PC), extractable for cleaning operations

• Screws, nuts and washers

- **HCK-GL**: zinc-plated steel screws with hexagon socket, nuts and washers.

- **HCK-GL-SST**: AISI 303 stainless steel screws with hexagon socket, AISI 304 stainless steel nuts and washers.

• Flat gaskets

- **HCK-GL**: NBR rubber O-Ring

- **HCK-GL-SST**: FKM type VITON[®] synthetic rubber O-Ring.

• Graduated contrast screen

Self-adhesive plastic material, resistant to oils, greases.

Fitted to the aluminium support.

• Maximum continuous working temperature

- **HCK-GL**: 100°C (with oil, water, glycol-based solutions).

- **HCK-GL-SST**: 130°C (with oil, water, glycol-based solutions). In laboratory tests these indicators showed an excellent resistance to temperatures up to 150/160°C for many hours with pressures of 5/6 bar.

* Registered trademark by Corning Inc.

** Registered trademark by DuPont Elastomers.

Technical data

In laboratory tests carried out with mineral oil type CB68 (according to ISO 3498) water or water/glycol-based solutions (50%), at 23°C for a relatively limited time, the values of pressure resistance were very high even higher than 35 bar.

If you need to use the indicator with other oils or fluids and under different pressure and temperature conditions, please contact ELESA Technical Department. In any case we suggest to verify the suitability of the product under the actual working conditions.

Special executions on request

- Polyamide based technopolymer float (from HCK.127) red colour.

- Expanded NBR float (from HCK.176) black colour with AISI 316 stainless steel spiral for special executions, viscous liquids, high temperatures.

- Column level window with visibility (l₂) superior to 452 mm and holes centre distance (f) for fixing up to 1.500 mm.

- Electric sensor bracket pre-set at the following temperatures: 50°C, 60°C, 70°C, 80°C.

- Packing rings in special material depending on the customer's needs.

- Built-in thermometer with red indication line.

- External scale thermometer (Fig. 1) with internal probe for fluid temperature.

- SLCK electric level sensor (Fig.2, from HCK.127) which can be fitted along the axis of the indicator according to the actual needs. With right (DX) or left (SX) connectors, normally closed (NC), normally open (NO).

- Special screw with nickel-plated brass tap (Fig. 3) to be fitted to the lower assembly end for any maintenance operation requiring the indicator exclusion.

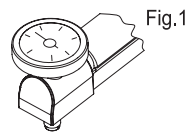
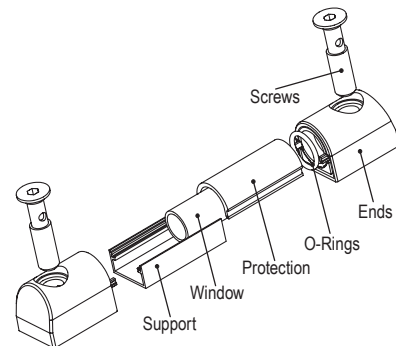

Fig.1

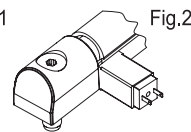

Fig.2

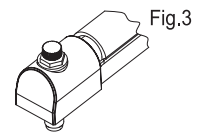
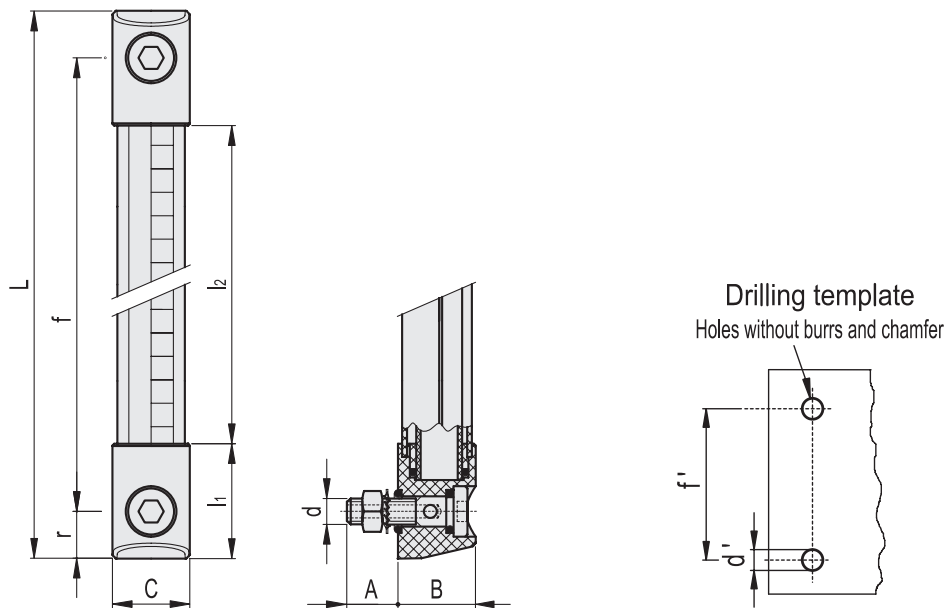

Fig.3



HCK-GL

Code	Description	f	d	A	B	C	L	l ₁	l ₂	r	d' ^{-0.2}	f'	C# [Nm]	⚖
111004	HCK.76-GL-M10	76	M10	20	33	33	113	35.5	42	18.5	10.5	76 ±0.2	12	183
111014	HCK.127-GL-M12	127	M12	20	33	33	164	46.5	71	18.5	12.5	127±0.5	12	220
111024	HCK.176-GL-M12	176	M12	20	33	33	213	46.5	120	18.5	12.5	176±0.5	12	250
111034	HCK.254-GL-M12	254	M12	20	33	33	291	46.5	198	18.5	12.5	254±0.5	12	298
111044	HCK.381-GL-M12	381	M12	20	33	33	418	46.5	325	18.5	12.5	381±0.5	12	377
111054	HCK.508-GL-M12	508	M12	20	33	33	545	46.5	452	18.5	12.5	508±0.5	12	455

HCK-GL-SST

Code	Description	f	d	A	B	C	L	l ₁	l ₂	r	d' ^{-0.2}	f'	C# [Nm]	⚖
111005	HCK.76-GL-SST-M10	76	M10	20	33	33	113	35.5	42	18.5	10.5	76 ±0.2	12	183
111015	HCK.127-GL-SST-M12	127	M12	20	33	33	164	46.5	71	18.5	12.5	127±0.5	12	220
111025	HCK.176-GL-SST-M12	176	M12	20	33	33	213	46.5	120	18.5	12.5	176±0.5	12	250
111035	HCK.254-GL-SST-M12	254	M12	20	33	33	291	46.5	198	18.5	12.5	254±0.5	12	298
111045	HCK.381-GL-SST-M12	381	M12	20	33	33	418	46.5	325	18.5	12.5	381±0.5	12	377
111055	HCK.508-GL-SST-M12	508	M12	20	33	33	545	46.5	452	18.5	12.5	508±0.5	12	455

Maximum tightening torque.