

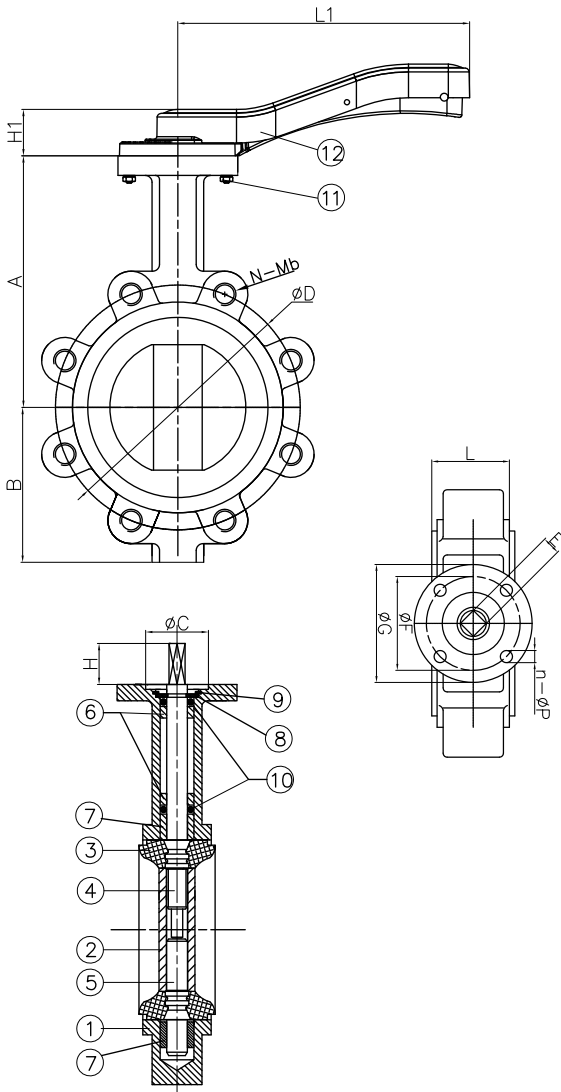

Ductile Iron Butterfly Valve Lugged & Tapped Type

Features

- Flange Mounting PN16 Only
- BS5155 (BS EN 593)
- ISO 5211 Direct Mount
- Lockable Handle
- Epoxy Coat Finish



Technical Data

Maximum Pressure 16 Bar
Working Temperature 0°C to + 90°C

Dimensions in mm

This data sheet is designed as a guide and should not be regarded as wholly accurate in every detail. We reserve the right to amend the specification of any product without notice.

Pressure/Temperature

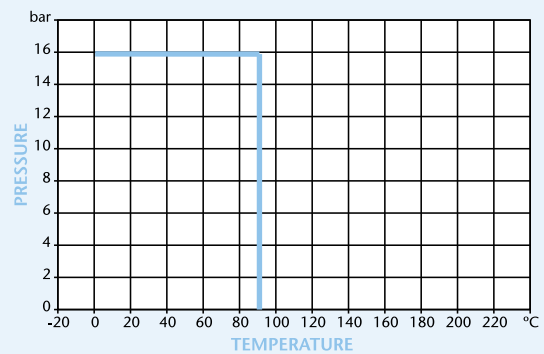

DN	50	65	80	100	125	150	200	250	300
A	142	154	161	179	193	204	250	282	326
B	75	80	91	110	125	137	178	208	241
C	56	56	56	56	56	56	71	71	71
D	125	145	160	180	210	240	295	355	410
E	11	11	11	11	14	14	17	22	22
F	70	70	70	70	70	70	102	102	102
G	90	90	90	90	90	90	125	125	125
H	19	19	19	19	19	19	25	30	30
H1	31	31	31	36	36	36	42	42	42
L	41.4	44	44.6	51.4	53.8	55.1	59.5	65	75.9
L1	176	176	176	225	225	225	300	359	359
N-Mb	4xM16	4xM16	8xM16	8xM16	8xM16	8xM20	12xM20	12xM24	12xM24
n-Øp	4x10	4x10	4x10	4x10	4x10	4x10	4x12	4x12	4x12
Torque	19	21	28	43	60	91	194	295	412
Kgs	3.55	3.95	5.25	7	8.65	10.1	18.2	26.8	35.5

N.	Part Name	Materials
1	Body	Ductile Iron GGG40
2	Disc	Ductile Iron / Nickel Plated
3	Seat	NBR
4	Upper Shaft	Stainless Steel 410
5	Lower Shaft	Stainless Steel 411
6	Short Bush	PTFE
7	Long Bush	PTFE
8	Split Pin	Spring Steel
9	Circlip	Spring Steel
10	O-Ring	EPDM
11	Bolt	Carbon Steel
12	Lever	DN 50-150 Aluminium DN200-300 DI