

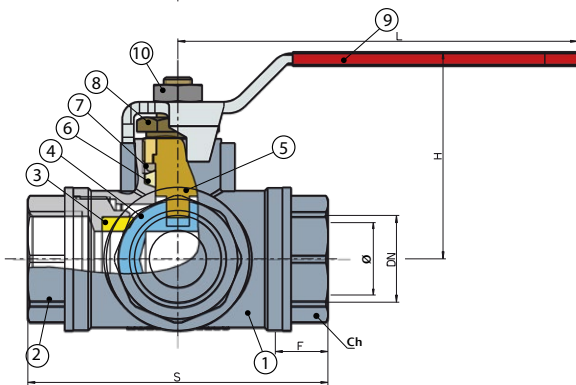

PN32 Brass 3 Way Ball Valve

Features

- Screwed BSP Parallel
- PTFE Seats & Seals
- Reduced Bore
- 'L' & 'T' Port

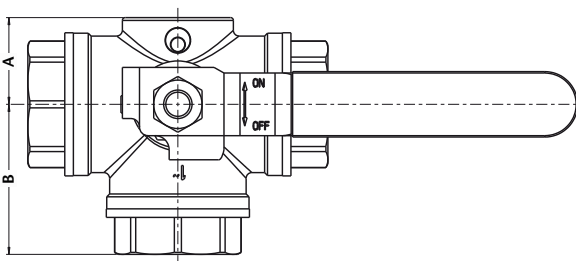

Pressure / Temperature

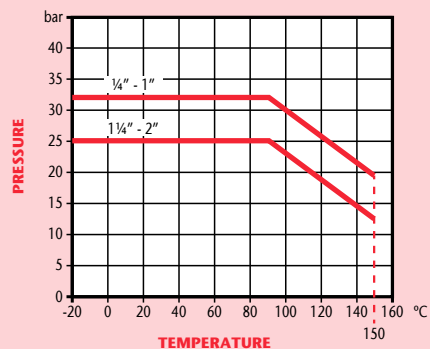

DN	1/4"	3/8"	1/2"	3/4"	1"	1 1/4"	1 1/2"	2"
S	74	74	80	90	105	115	138	161
H	58	58	60	64	73	79	100	105
B	37	37	39	46	52	58	69	80
A	22	22	24	28	31	35	42	48
F	12	12	14	16	19	21	23	26
Ch	22	22	29	34	42	50	57	68
L	90	90	125	125	140	140	220	220
ø	10	10	12	15	20	25	32	40
Kgs	0.69	0.73	0.82	1.04	1.74	2.70	4.32	8.37

N.	Part Name	Materials
1	Body	Brass/Nickel Plated
2	Body End	Brass/Nickel Plated
3	Seat	PTFE
4	Ball	Brass/Chrome Plated
5	Stem	Brass
6	Stem Seat	PTFE
7	Packing Nut	Brass
8	Lever	Steel/PVC Coated
9	Nut	Steel/Zinc Plated

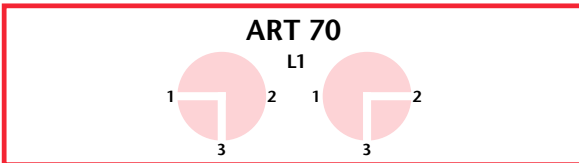

Ball Positions

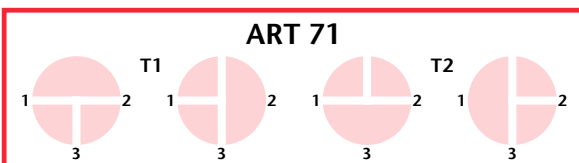

Ball Positions

Technical Data

Max Pressure	1/4"-1"	32 Bar
	1/4"-2"	25 Bar
Working Temperature	-20°C to +150°C	

Dimensions in mm

This data sheet is designed as a guide and should not be regarded as wholly accurate in every detail. We reserve the right to amend the specification of any product without notice.