

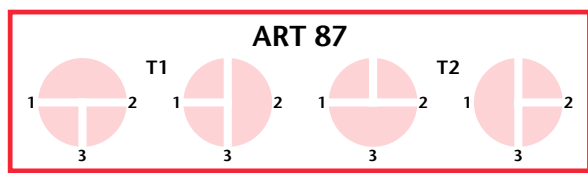

### PN30 Brass 3 Way Ball Valve

#### Features

- Screwed BSP Parallel
- PTFE Seals
- ISO 5211 Direct Mount
- Levers Available
- 'T' & 'L' Port

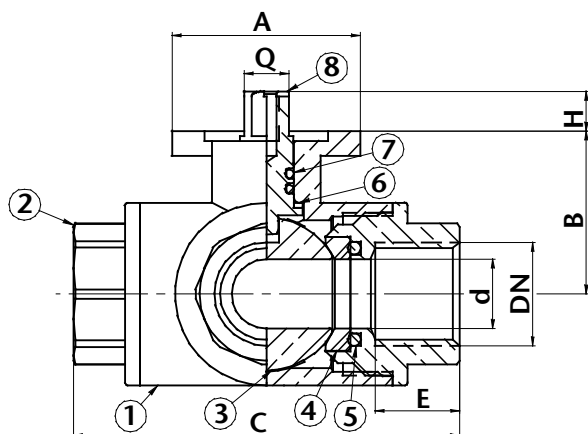

Ball Positions

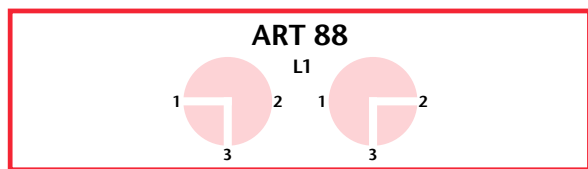

Ball Positions

Technical Data		
Max Pressure	1/4"-3/4"	30 Bar
	1"-1 1/4"	20 Bar
	1 1/2"-2"	16 Bar
Working Temperature	-20°C to +120°C	

Dimensions in mm

This data sheet is designed as a guide and should not be regarded as wholly accurate in every detail. We reserve the right to amend the specification of any product without notice.

#### Pressure / Temperature

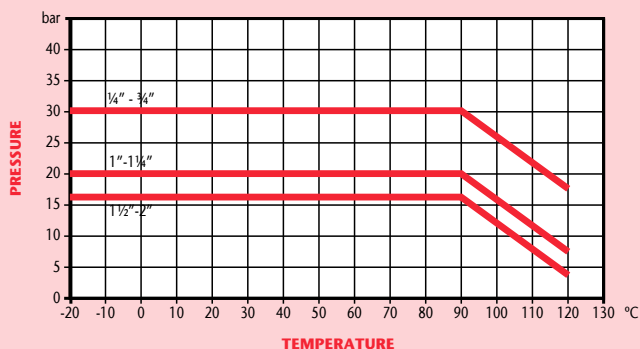

DN	1/4"	3/8"	1/2"	3/4"	1"	1 1/4"	1 1/2"	2"
d	10	10	14	19	24	30	38	48
A	38	38	38	50	50	50	70	70
B	30	30	33	42	47	52	70	79.5
C	65	65	78	87	105	118	134	161
E	15	15	17	18	21	23.5	23.5	27.5
H	10	10	10	12	12	12	16	16
Q	9	9	9	11	11	11	14	14
ISO5211	F03	F03	F03	F05	F05	F05	F07	F07
Torque	3	3	4	10	13	13	20	25
Kgs (ART 87)	0.42	0.39	0.57	0.88	1.47	1.99	3.64	6.15
Kgs (ART 88)	0.42	0.39	0.57	0.90	1.49	2.05	3.73	6.29

Torque calculated at zero pressure includes 25% safety, add 25% for dry duty.

N.	Part Name	Materials
1	Body	Brass/Chrome Plated
2	Body End	Brass/Chrome Plated
3	Ball	Brass/Chrome Plated
4	Ring	PTFE
5	'O' Ring	Viton
6	Washer	PTFE
7	'O' Ring	Viton
8	Stem	Brass/Nickel Plated