



## MATERIALS

BODY	DT 58 - UNI 5705 - NICKEL-PLATED
NEEDLE	X 10 CR NI S 1809 - UNI 6900
OR	NITRILE
ANTIEXTRUSION RING	PTFE
KNOB	GD AL SI 12 - UNI EN AB 46100
KNOB (MP)	ABS

## EXAMPLE FOR ORDERING

ACCESSORIES BY REQUEST					
	CODE	TYPE	PANEL RING NUT	VITON SEAL	KNOB ABS
BRASS	FT 1251/2-01	38	G	V	MP
STAINLESS STEEL	FT 2251/2-01	14	G	-	MP

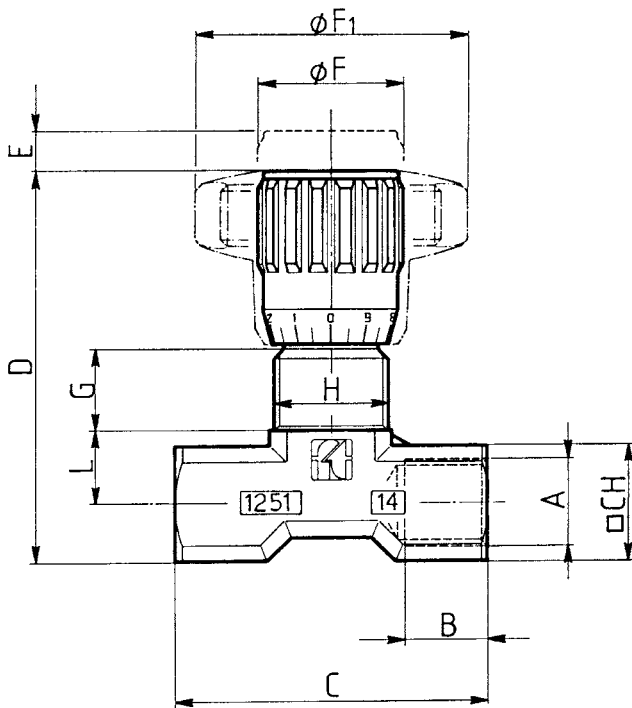

## DIMENSIONS

TYPE	A UNI 338	B	C	D	E	ØF	ØF1	G	H	L	□ CH	WEIGHT KG
18	1/8"G	8	40	55	4	22	40	12	M15x1	9,5	15	0,105
14	1/4"G	12	46	57	4,5	22	40	11,5	M17x1	11,5	18	0,122
38	3/8"G	13	55	69	7	27	50	12,5	M20x1	15	22	0,233
12	1/2"G	16	70	82	10	33	70	13	M25x1,5	19	27	0,455
34	3/4"G	20	91	100	12	38	80	15	M30x1,5	22	34	0,860



## DOUBLE-ACTING CONTROL VALVES FEMALE-FEMALE IN LINE

They allow the regulation of flow in both directions.

Notable from an aesthetical point of view they are built with materials which are suitable also for applications with fluids different from oil (such as: water, gas and liquids in general).

As an alternative to FT 257/2 (suitable up to 400 bar) where the working pressure does not exceed 210 bar and where ferrous materials cannot be used.

They have the same characteristics as the FT 257 series:

- accurate flow regulation;
- efficient metallic sealing;
- simple setting of flow rates;
- secure against accidental needle withdrawal;
- secure needle position with locking screw inserted in the knob;
- provision for panel mounting, for which special lock nut (G) is supplied on request.

For use with pressure up to 210 bar.

### On request

- Versions AISI 316 Code FT 2251/2-01
- Viton (V) seals
- NPT threads
- ABS (mp)Knob
- Complete with lock nut (G)



# FT 1251/2-01

## TECHNICAL DATA

TYPE	FLOW SQ MM <sup>2</sup>	MAX WORKING PRESSURE BAR	WORKING TEMPERATURE °C	FILTRATION GRADE μM
18	7,07	210	-20°/+100°	25
14	12,57	210	-20°/+100°	25
38	19,64	210	-20°/+100°	25
12	50,27	210	-20°/+100°	25
34	78,54	210	-20°/+100°	25

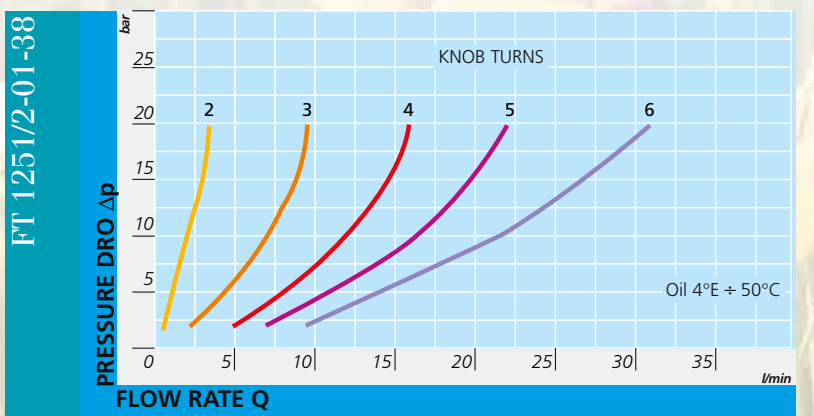
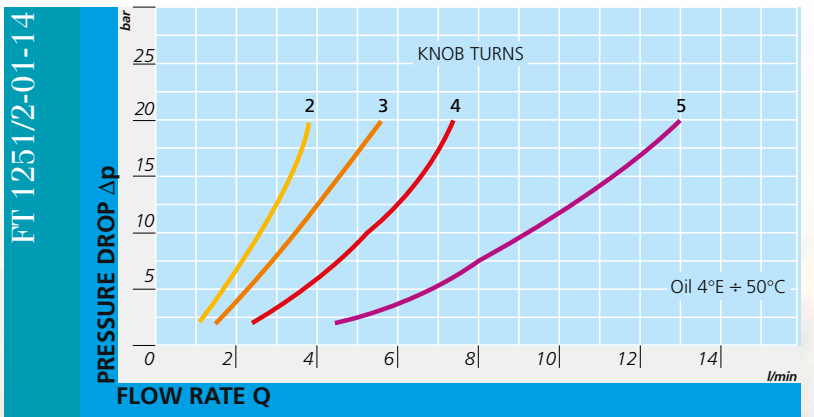
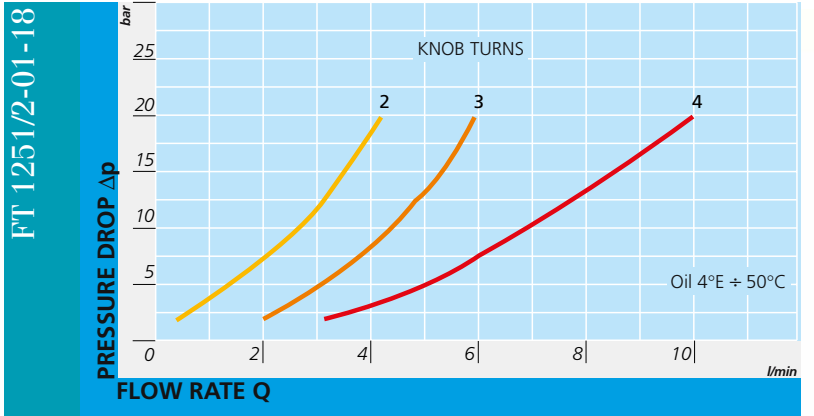

# FLOW RATE CURVES

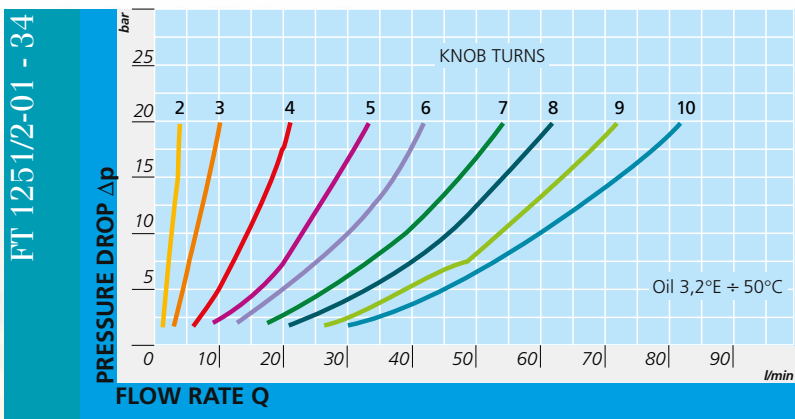
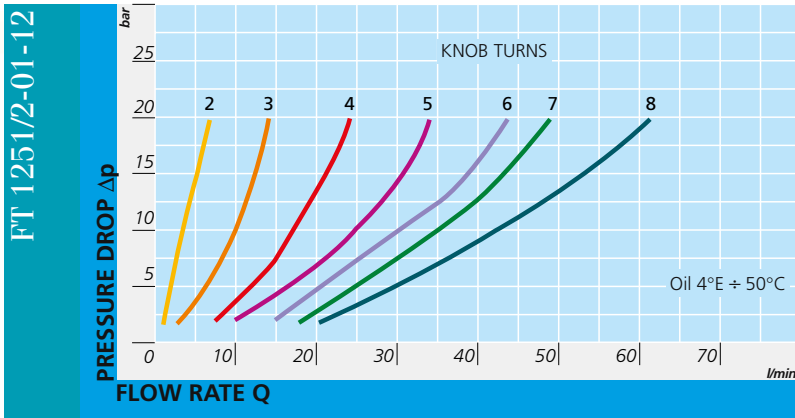

FT 1251/2-01

# FT 1250

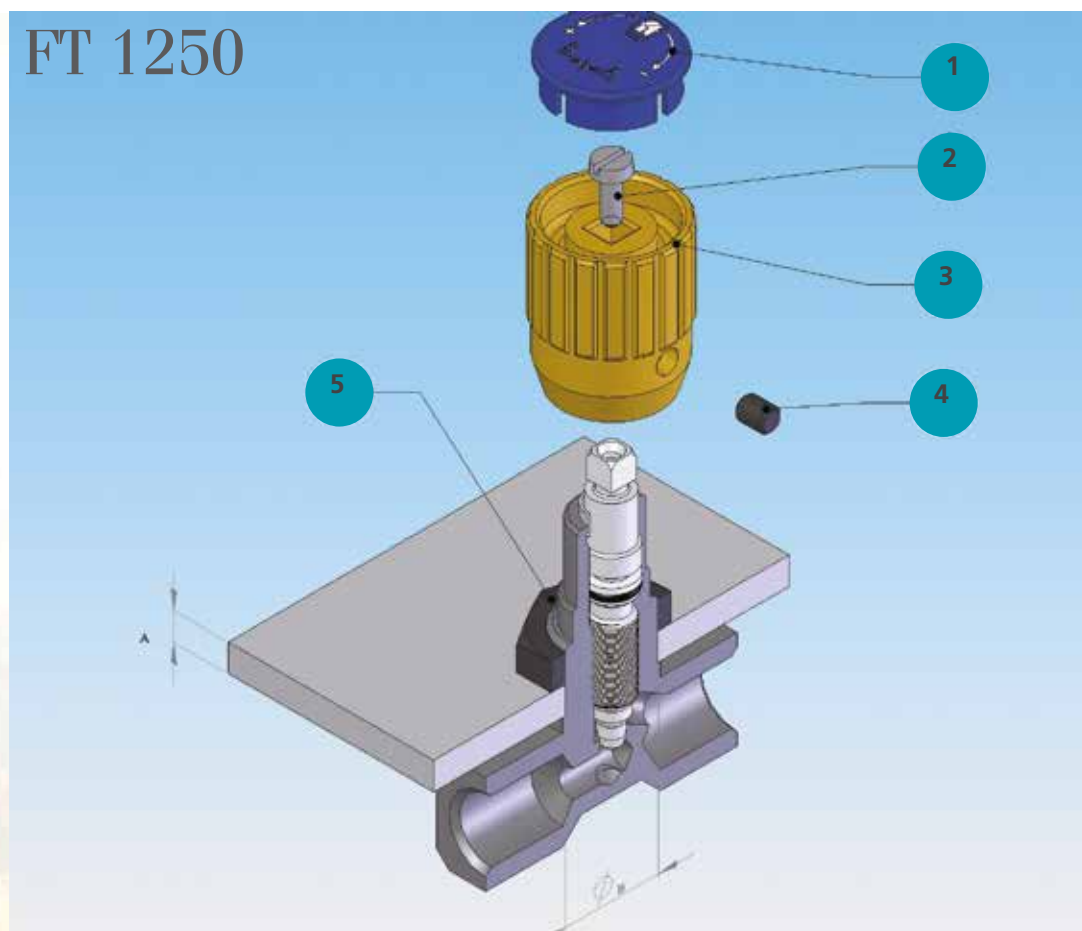

## ASSEMBLY INSTRUCTION

1°	LOOSEN SCREW PRESSURE DOWEL (4)
2°	REMOVE PLUG (1)
3°	REMOVE SCREW (2)
4°	PULL OFF KNOB (3)
5°	INSERT RING NUT (5), ON REQUEST IT IS SUPPLIED WITH THE VALVE
(A)	MAX. THICKNESS
(B)	PANEL HOLE $\varnothing$

TYPE VALVE	THICKNESS PANEL A MAX	PANEL HOLE $\varnothing$ B
18	5	16
14	5	18
38	5	21
12	6	26
34	6	31