

GERADE ANSCHWEISS-STUTZEN STRAIGHT WELDING ADAPTORS

metrisch - fein
mit 60°-Innenkonus

metric - pitch 1,5 mm and 2 mm
with 60°-cone

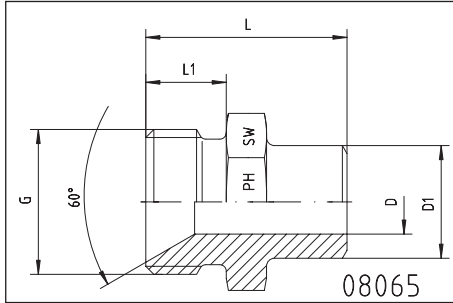

Gewinde Thread G	ca. Maße approx. dimensions					Bestellzeichen Order-Code
	L	L1	D	D1	SW	
M 12 x 1,5	24	10	3,5	6	12	0806504-02
M 14 x 1,5	25	10	4,5	8	14	0806507-04
M 16 x 1,5	25	10	6,0	10	17	0806509-05
M 18 x 1,5	25	10	8,0	14	19	0806511-06
M 22 x 1,5	27	12	10,5	17	22	0806514-08
M 26 x 1,5	28	12	13,0	21	27	0806517-10
M 30 x 1,5	28	12	15,5	25	30	0806521-12
M 38 x 1,5	30	14	21,0	30	41	0806526-16
M 45 x 1,5	31	14	28,0	38	46	0806533-20
M 52 x 1,5	32	14	35,0	44	55	0806541-24
M 65 x 2	36	17	45,0	57	65	0806551-32
M 78 x 2	36	17	55,0	64	80	0806561-40
M 90 x 2	47	22	67,0	76	90	0806571-48
M 100 x 2	47	22	77,0	89	100	0806581-56