

Threaded Cylinders

HT Series

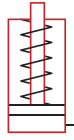

- Ideal for frame pulling machines
- Threaded plunger and base
- Single acting cylinders with spring return
- Removable threaded Plunger adapter for attaching accessories to plunger end and base
- Maximum working pressure: 10,000 psi / 700 bar



80%

Safety Practices

Good industry practice recommends not exceeding 80% of maximum rated capacities of all our products.

Combo Kits

Most cylinders are available in easy to order kits: cylinder, gauge, couplers, hose and pump.

Safety Instructions

Visit our DO'S and DON'TS section to review the best methods of operation. Always be prepared.

High-Flow Couplers

High-Flow Coupler: CH38F is included on all models (except where specified).

HT Series

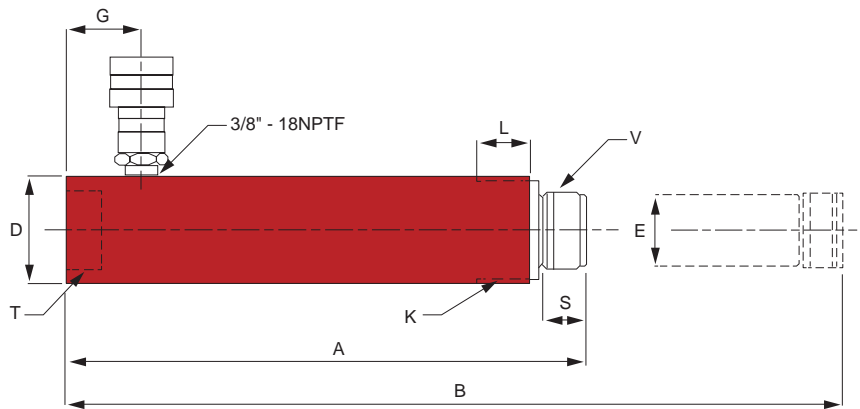

Cylinder Capacity	Stroke (mm)	Model Number	Cylinder Effective Area (cm ²)	Oil Capacity (cc)	Collapsed Height A (mm)	Extended Height B (mm)	Weight (kg)
10 Ton 89 kN	151	HT1006	14.5	218	291	442	4.8
	253	HT1010	14.5	365	393	646	6.4
20 Ton 178 kN	131	HT2005	33.2	421	299	430	10.0

Model Number	Outside Dia. D (mm)	Plunger Dia. E (mm)	Base to Inlet Port G (mm)	Collar K	Collar Thread Length L (mm)	Saddle Height S (mm)	Base Threads T	Plunger Threads V
HT1006	57	38	42	2.25"-14UN	29	24	1.25" -11.5 NPSM	1.25" -11.5 NPSM
HT1010	57	38	42	2.25"-14UN	29	24	1.25" -11.5 NPSM	1.25" -11.5 NPSM
HT2005	85	57	47	3.31"-12UN	50	36	2" -11.5 NPTF	2" -11.5 NPSM