



Double Acting Hollow Plunger Cylinders

HDC Series



HDC3010

HDC6006



HDC10001

Capacity:

30 - 150 Tons

Stroke:

38 - 257 mm

Max. Operating Pressure:

700 BAR

Min. - Max. Height:

165 - 718 Inches



Related Product: Gauges

Reduce the risk of overloading your product by using a gauge. A variety of graduations and types to suit any need.

pg 65



Combo Kits

Most cylinders are available in easy to order kits: Cylinder, Gauge, Couplers, Hose and Pump.

pg 60



Related Product: Hoses

We offer a variety of hoses, fittings, lengths and materials.

pg 67

- Ideal for pushing and pulling applications.
- Dual wipers help prevent contamination
- CH38F - 3/8" high flow female coupler
- Hard chrome plunger prevents rust and corrosion
- Hardened steel seat

Cylinder Capacity		Stroke (mm)	Model Number	Oil Capacity		Collapsed Height (mm)	Extended Height (mm)	Center Hole I.D. (mm)	Plunger O.D. (mm)	Max Pressure (BAR)	Weight (kg)
Push	Pull			Push (cc)	Pull (cc)						
30 Ton 267 kN	20Ton 178 kN	178	HDC3007	492	328	331	509	33	63	700	19.5
		257	HDC3010	1051	658	432	689	33	63	700	25.7
60 Ton 534 kN	44 Ton 391 kN	89	HDC6003	750	500	248	337	54	92	700	29.8
		165	HDC6006	1390	926	324	489	54	92	700	36.8
		257	HDC6010	2165	1443	438	695	54	92	700	51.0
100 Ton 890 kN	71 Ton 632 kN	38	HDC10001	545	347	165	203	79	125	700	33.4
		76	HDC10003	1089	694	254	330	79	125	700	51.4
		152	HDC10006	2169	1388	343	495	79	125	700	69.5
		257	HDC10010	3679	2345	461	718	79	125	700	90.2
150 Ton 1334 kN	82.8 Ton 737 kN	203	HDC15008	4247	2170	349	552	100	150	700	108.5

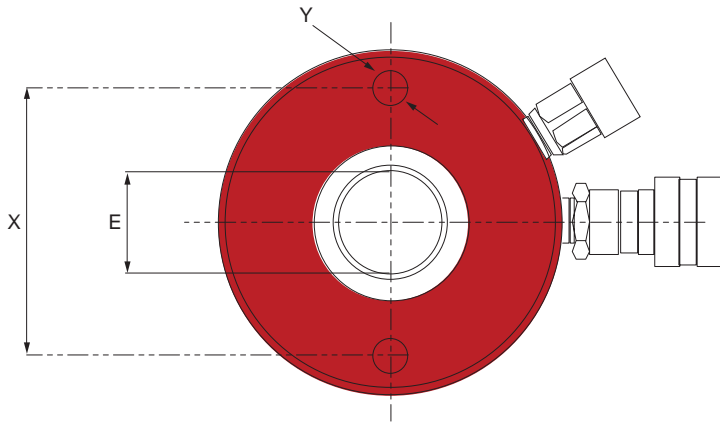

HDC Series



Safety Practices

Good industry practice recommends not exceeding 80% of maximum rated capacities of all our products.



Relief Valve

All double acting cylinders are equipped with a pressure relief valve located next to the retract port. These pressure relief valves help prevent cylinder over pressurization on the return port side of the cylinder.



High-Flow Couplers

High-Flow Coupler: CH38F is included on all models (except where specified).



Safety Instructions

Visit our DO'S and DON'TS section to review the best methods of operation. Always be prepared.

pg.102

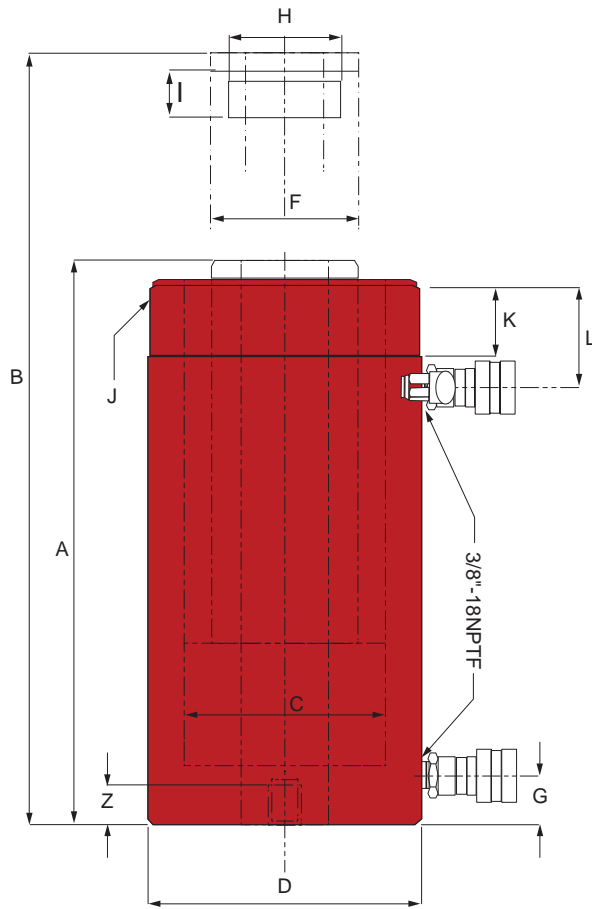

Model Number	Min. Height A (mm)	Max. Height B (mm)	Dia. of Center Tube C (mm)	O.D. D (mm)	I.D. E (mm)	O.D. F (mm)	Base to Inlet Port G (mm)	Top to Return Port L (mm)	Internal Thread H	Internal Thread Length I (mm)	Collar Thread		Base Mounting Hole		
											Dia. J (mm)	Length K (mm)	Bolt Circle X (mm)	Thread Y	Thread Depth Z (mm)
HDC3007	331	509	85	114	33	63	23	60	1"-16UN	24	4½"-12N	42	92	⅝"-16UNC	14
HDC3010	432	689	85	114	33	63	23	60	1"-16UN	24	4½"-12N	42	92	⅝"-16UNC	14
HDC6003	248	337	125	159	54	92	27	67	2¾"-16UN	21	6¼"-12N	49	130	½" 13UNC	14
HDC6006	324	489	125	159	54	92	27	67	2¾"-16UN	21	6¼"-12N	49	130	½" 13UNC	14
HDC6010	438	695	125	159	54	92	27	67	2¾"-16UN	21	6¼"-12N	49	130	½" 13UNC	14
HDC10001	165	203	165	213	79	125	27	44	4"-16UN	27	-	-	178	⅝" 11UNC	19
HDC10003	254	330	165	213	79	125	27	86	4"-16UN	27	8⅝"-12N	60	178	⅝" 11UNC	19
HDC10006	343	495	165	213	79	125	27	86	4"-16UN	27	8⅝"-12N	60	178	⅝" 11UNC	19
HDC10010	461	718	165	213	79	125	27	86	4"-16UN	27	8⅝"-12N	60	178	⅝" 11UNC	19
HDC15008	349	552	190	248	100	150	38	60	-	-	-	-	-	-	-