

Hydraulic valves

Overcenter valves

Double acting balanced overcenter (line)

Page: 1/1

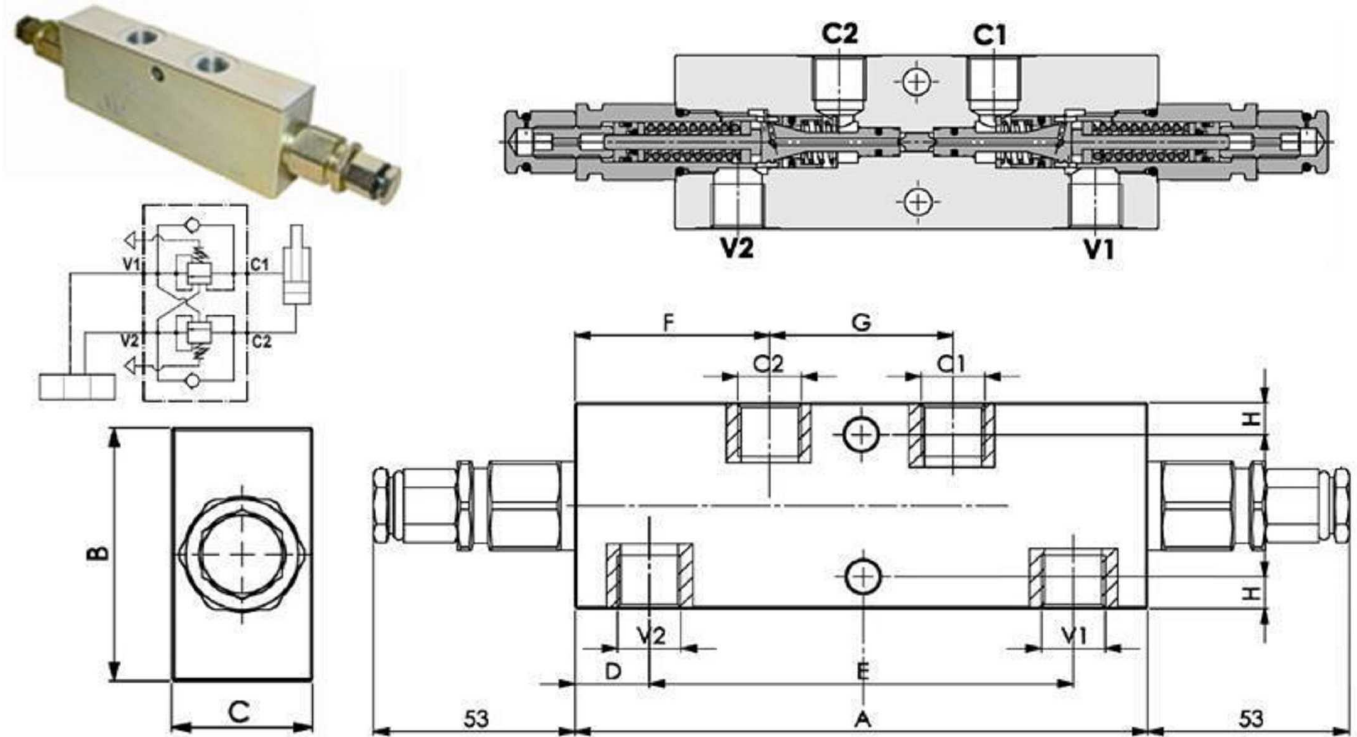

R1=C1, C2, V1, V2

Pilot ratio: 1:4,25 (1 : 8 and 1 : 11 on request)

Material: Body is steel made zinc plated.

Max.flow: 50 l/min

Max.press: 350 bar

Adjustment means: Leakproof screw

Assembly: with control valve with any spool

Part n°	R1	Max. flow (l/min)	Max. Press. (bar)	Setting (bar)	Reg. rate (bar)	Press. increase (bar/turn)	A	B	C	D	E	F	G	H	I
VT0160063520	3/8" BSP	50	350	170	60 - 210	70	150	55	30	19	112	51	48	8,5	8,5
VT0160063535	3/8" BSP	50	350	280	80 - 350	120	150	55	30	19	112	51	48	8,5	8,5
VT0160085020	1/2" BSP	50	350	170	60 - 210	70	150	65	35	19	112	51	48	11	8,5
VT0160065035	1/2" BSP	50	350	280	80 - 350	120	150	65	35	19	112	51	48	11	8,5

*** Review attached PDF***