

Valves series AX1 - Non-sparking coil Ex nA

1/4", 3/2 - 5/2 - 5/3, IN LINE and NAMUR interface, electrically operated Ex nA



Standard executions		
Version	Symbol	Code
3/2 NC		For code key see the table below
3/2 NO		
3/2 solenoid/solenoid		
5/2 solenoid/spring		
5/2 solenoid/solenoid		
5/2 solenoid/solenoid differential		
5/3 closed centres		
5/3 open centres		
5/3 pressurised centres		

New



New series of "AX" valves with functions 3/2 - 5/2 - 5/3 connection in line on the body or NAMUR. Electric and electric servo pilot.

They are manufactured in AISI 316L stainless steel, especially suitable in the food, chemical, pharmaceutical, Oil & Gas and mining industry.

AX valves are manufactured according to 2014/34/EU Directive to be used in potentially explosive environment.

Solenoid operator with a special coil for pneumatic application in potentially explosive environment (group II).

Solenoid system is conforming to 2014/34/EU Directive, certified:

II 3G Ex nA IIC T5 Gc X
II 3D Ex tc IIIC T95°C Dc X

Connectors have to be ordered separately:

For connector type A12209N/ATEX

see page 2.210.50

Code key						
Series	Actuation	Size	Function	Hazardous areas	Voltages	
AX1 = Standard AXX1 = Completely in stainless steel AX1N = NAMUR AXX1N = NAMUR Completely in stainless steel	E = electrical Ø9 K = electrical Ø9 external air pilot	2 = 1/4 Gas 2N = 1/4 NPT	30 = 3/2 NC 31 = 3/2 NO 32 = 3/2 solenoid/solenoid 50 = 5/2 solenoid/spring 51 = 5/2 solenoid/solenoid 52 = 5/2 solenoid/solenoid differential 70 = 5/3 CC 71 = 5/3 OC 72 = 5/3 PC	XX = II 3G Ex nA IIC T5 Gc X II 3D Ex tc IIIC T95°C Dc X	B = 12 VDC C = 24 VDC *	F = 24 VAC * I = 110 VAC * O = 220 VAC *
					* = Standard voltages	

Technical data						
Fluid		Compressed filtered air with or without lubrication. Lubrication, if started, must be continued.				
Threaded connection		1/4 Gas - 1/4 NPT				
Pressure range		Spring return: 1,5 ÷ 10 bar	Bistable: 1 ÷ 10 bar	3 positions: 2.5 ÷ 10 bar		
Temperature range		-15°C ÷ +50°C				
Ø Orifice		8 mm				
Flow		1.100 NI/min at 6 bar with ΔP 1 bar				
Mounting		In any position (vertical assembly is not recommended for bistable valves subjected to vibration)				
Manual override		Bistable				
Electrical characteristic	Nominal voltage	12 VDC	24 VDC	24 VAC	110 VAC	220 VAC
	Frequency	-	-	50 / 60 Hz	50 / 60 Hz	50 / 60 Hz
	Nominal current	0.250 A	0.120 A	0.208 A	0.045 A	-0.023 A
	Nominal power	3 W	3 W	5 VA	5 VA	5 VA
	Duty cycle	100% ED				
	Temp. class	T5				
Response time (at 6 bar)		Energising: - ms De-energising: - ms		Energising: - ms De-energising: - ms		Energising: - ms De-energising: - ms
Materials	(1) Body:	Stainless steel AISI 316L				
	(2) Cover:	Stainless steel AISI 316L				
	(3) Spool:	Hard anodized aluminium (AX series) Stainless steel AISI 316 (AXX series)				
	(4) Distancers:	Fortron 1140L4 (AX series) Stainless steel AISI 316 (AXX series)				
	(5) Seals:	Hydrogenate Nitrile Butadine Rubber (HNBR)				
	(6) Spring	Stainless steel				
	(7) Operator:	Stainless steel				
	(8) Coil:	Thermoset resin				

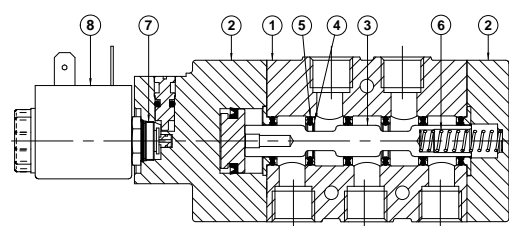

Valves series AX1 - Non sparking coil Ex nA
 1/4", 3/2 - 5/2 - 5/3, IN LINE interface, electrically operated Ex nA

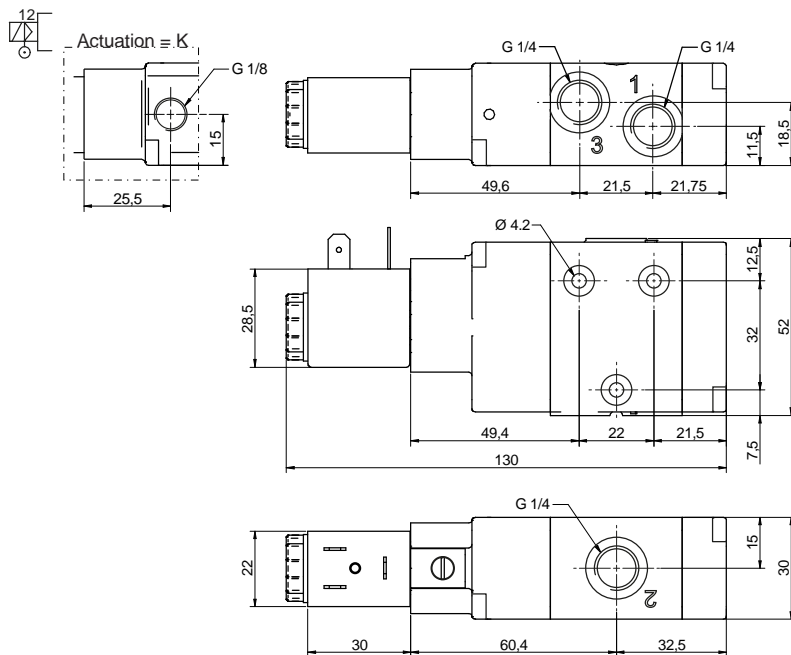

Version	Symbol	Code	Item
3/2 NC			AX1E230XX*
3/2 NO			AX1E231XX*
3/2 NC external air pilot			AX1K230XX*

* For coil voltage: see code key at page 5.81.1

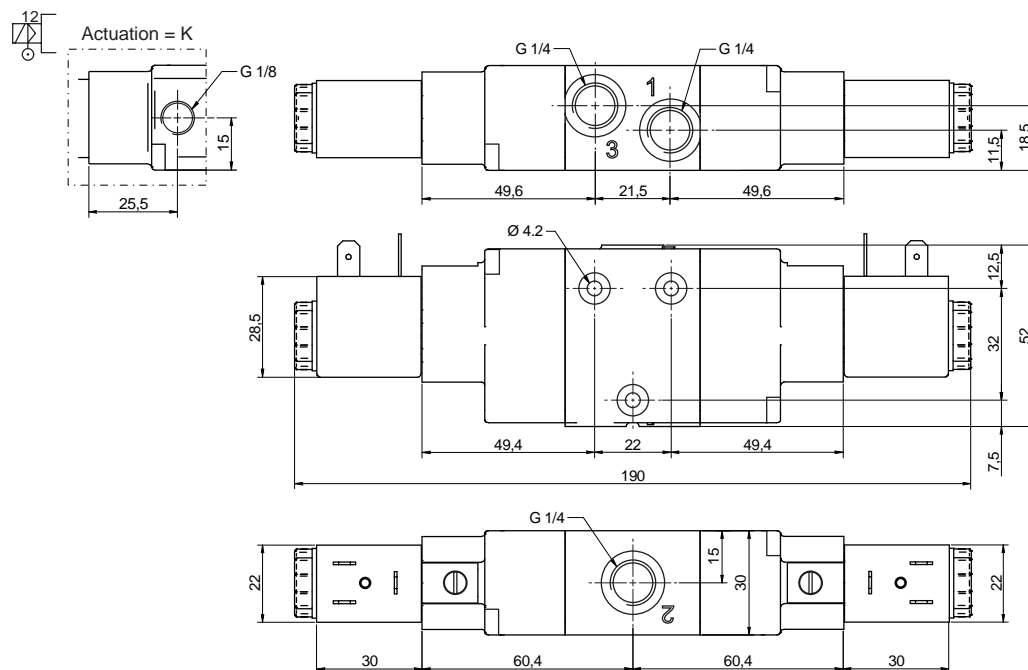

Version	Symbol	Code	Item
3/2 solenoid/solenoid			AX1E232XX*
3/2 solenoid/solenoid external air pilot			AX1K232XX*

* For coil voltage: see code key at page 5.81.1

Valves series AX1 - Non sparking coil Ex nA
 1/4", 3/2 - 5/2 - 5/3, IN LINE interface, electrically operated Ex nA

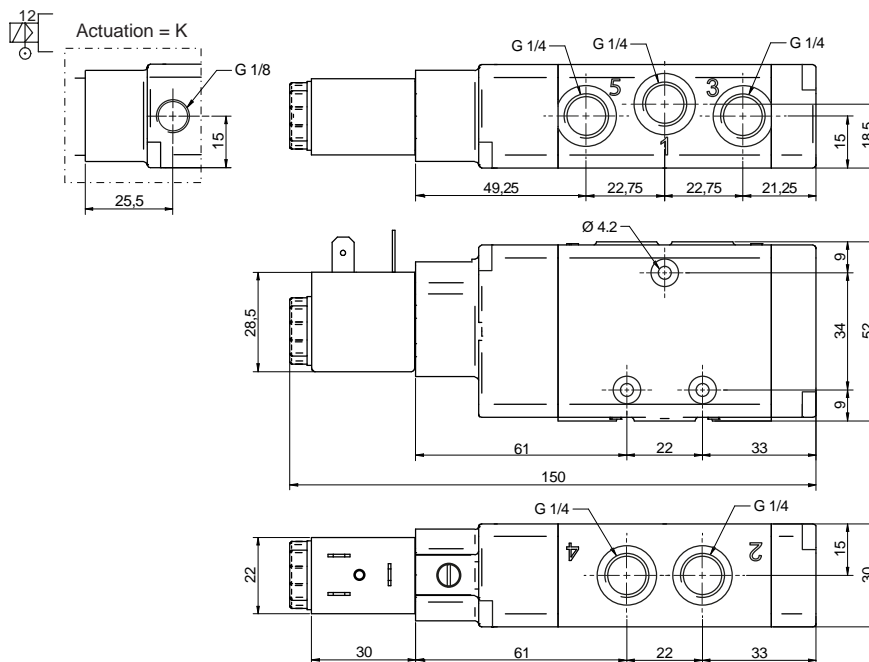

Version	Symbol	Code	Item
5/2 solenoid/spring			AX1E250XX*

* For coil voltage: see code key at page 5.81.1

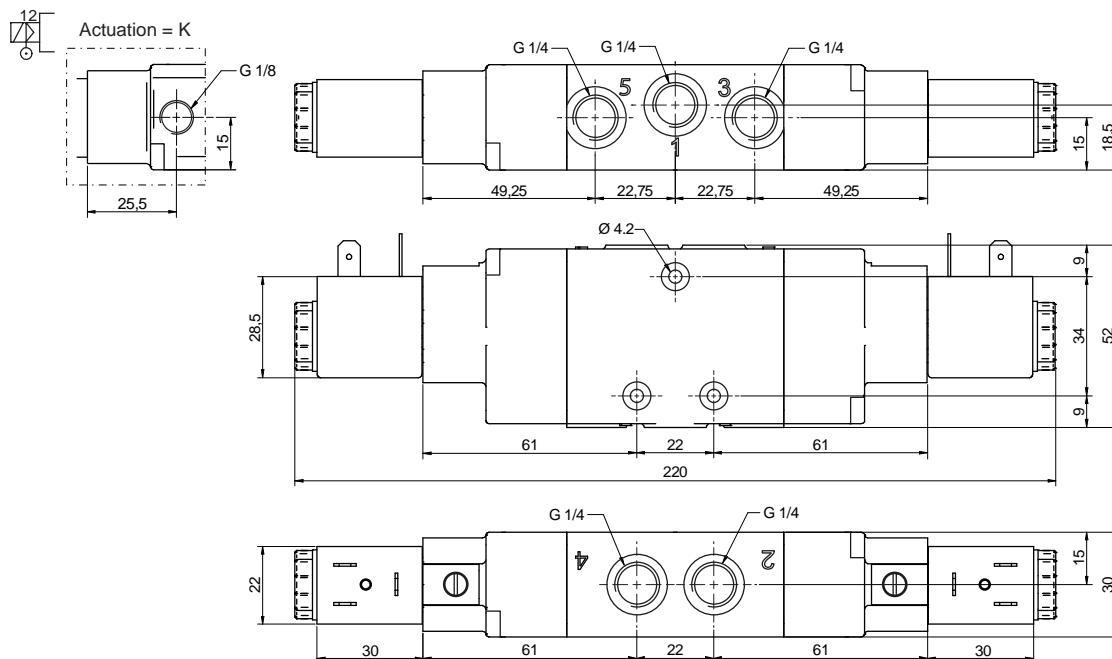

Version	Symbol	Code	Item
5/2 solenoid/solenoid			AX1E251XX*
5/2 solenoid/solenoid differential			AX1E252XX*

* For coil voltage: see code key at page 5.81.1

Valves series AX1 - Non sparking coil Ex nA
 1/4", 3/2 - 5/2 - 5/3, IN LINE interface, electrically operated Ex nA

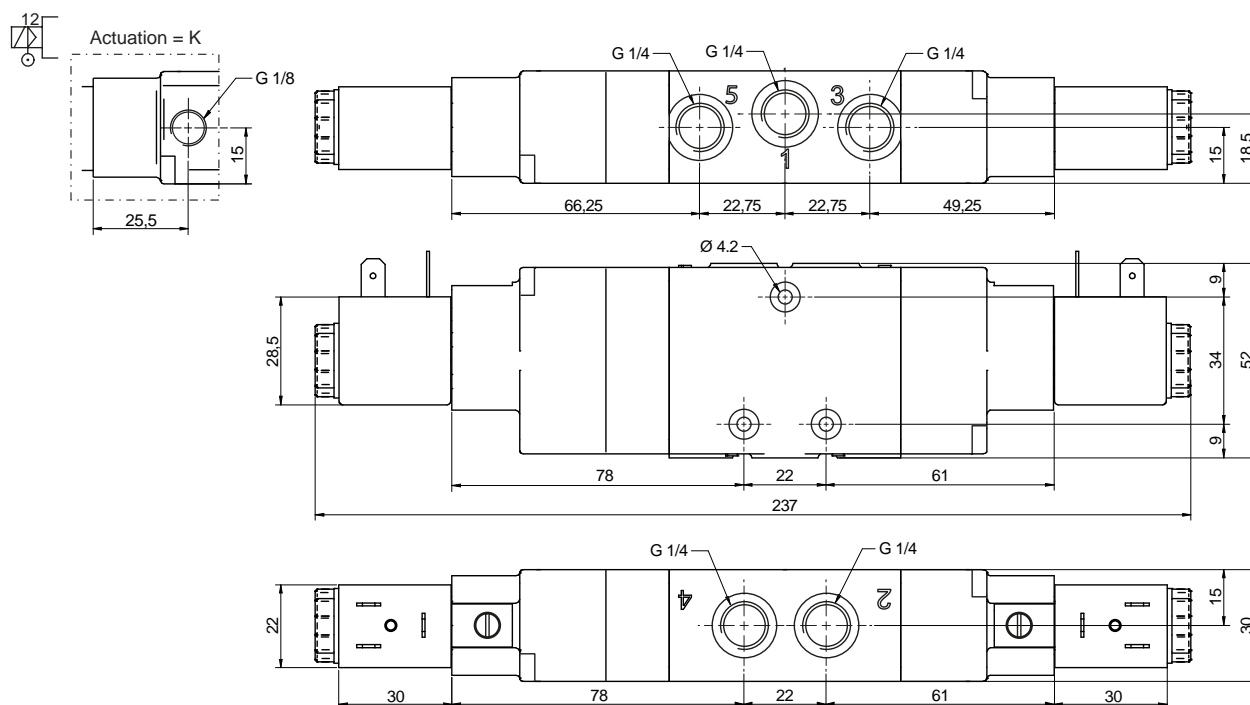

Version	Symbol	Code	Item
5/3 closed centres			AX1E270XX*
5/3 open centres			AX1E271XX*
5/3 pressurised centres			AX1E272XX*

Version	Symbol	Code	Item
5/3 closed centres, external air pilot			AX1K270XX*
5/3 open centres, external air pilot			AX1K271XX*
5/3 pressurised centres external air pilot			AX1K272XX*

* For coil voltage: see code key at page 5.81.1

