



YB-P16AP

Global Flex Swaging Machine

Easy to use, lightweight and compact in size, the YB-P16AP is ideal for use in a workshop or on-hose replacements.

The YB-P16AP is air pumped operated, requiring an 80-100 PSI air supply to operate effectively.

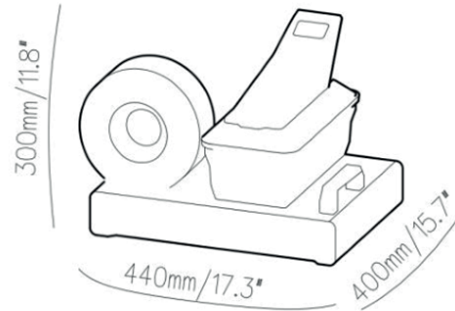

GLOBALFLEX

TECHNICAL DATA

Max crimping dia (mm)	10 - 45
Max crimping dia (inches)	0.39 - 1.77
Max crimping force (kN)	955
Max crimping force (tonnage)	95
Cycle time 10mm (s)	
Hose size ID (inches)	1
Die set series	P16
Max opening (mm)	+20
Max opening without dies (mm)	59
Master die D/L (inches)	1.54/2.52
Motor power (kW/HP)	-
Oil tank volume (L)	-

P16 DIES

DieSetNo	Crimping Range	ID (mm)	L (mm)
P16/06*	6.0 - 8.0	6	55
P16/08*	8.0 - 10.0	8	55
P16/10*	10.0 - 12.0	10	55
P16/12*	12.0 - 14.0	12	55
P16/14	14.0 - 16.0	14	55
P16/16	16.0 - 19.0	16	55
P16/19	19.0 - 23.0	19	55
P16/23	23.0 - 27.0	23	55
P16/27	27.0 - 31.0	27	65
P16/31	31.0 - 38.0	31	65

*Non standard dies



Hydraulic Hose & Fittings

Looking for hydraulic hose and fittings to go with your new swaging machine? We stock large quantities of hydraulic hose and fittings for use across every industry including; 1 wire, 2 wire, 4 wire and 6 wire hose, and fittings available in mild or stainless steel.

Looking to start a mobile hose replacement business?

We have a recommended starting stock list for any new van, speak to our sales team to discuss your specific needs.

30+ Years in the Hydraulic Industry

01472 806 037

www.hydraulicmegastore.com | hello@hydraulicmegastore.com

Unit 3 Estate Road 5, South Humberside Industrial Estate, Grimsby, North East Lincs, DN31 2TG

