

PART NUMBER	DESCRIPTION
HP050044-1	Aluminium manifold C/W relief valve, check valve & cavity plug
HP150001-8	8 Litre plastic hydraulic reservoir
HP4421-24	24 Volt 2.0kW D.C. motor

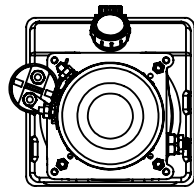
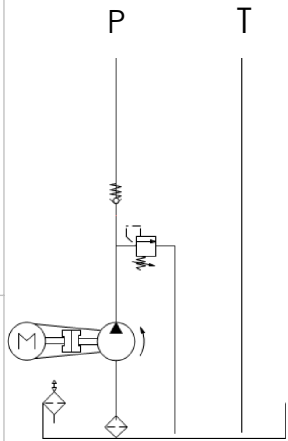
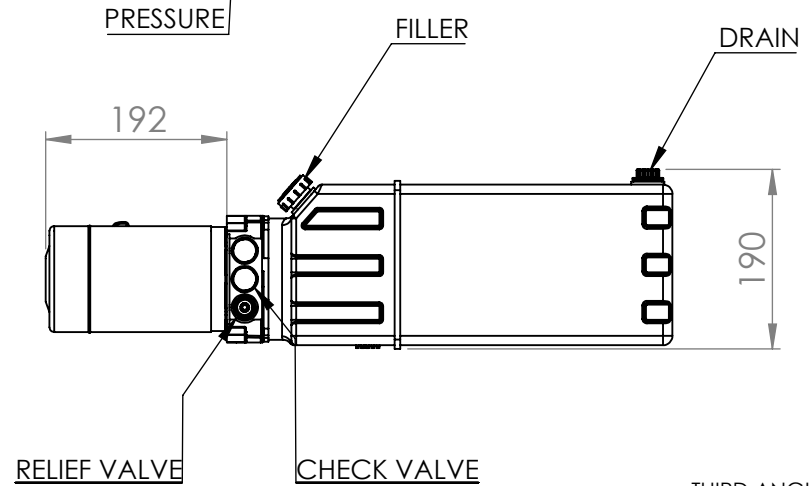
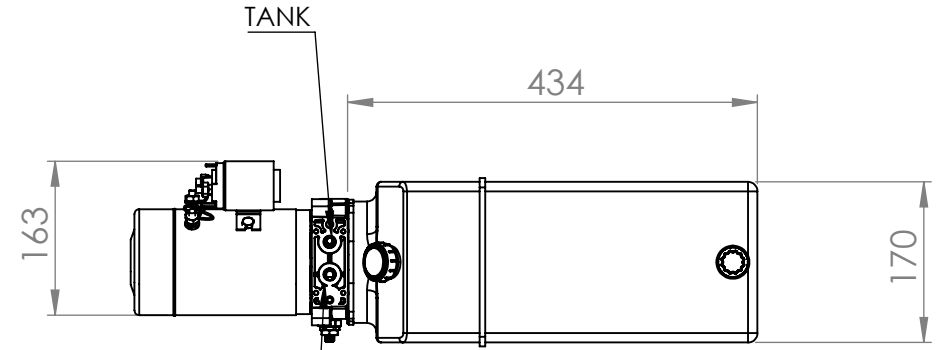
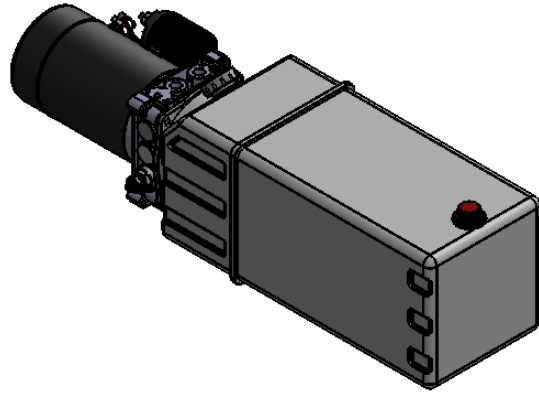
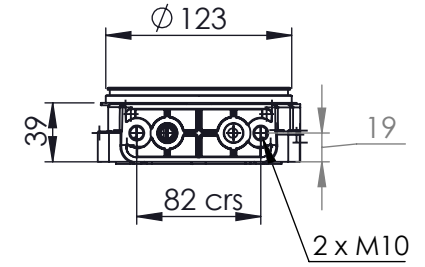

THIRD ANGLE PROJECTION

HYDRA PRODUCTS

Hydraproducts Ltd, www.hydraproducts.co.uk +44 1452 523352
It is an infringement of the Originators copyright in this drawing to copy or communicate its contents to any third party without the consent of Hydraproducts.

UNLESS OTHERWISE SPECIFIED:
DIMENSIONS ARE IN MILLIMETERS
TOLERANCES:
LINEAR: 2 DECIMAL PLACES ± 0.05
1 DECIMAL PLACE ± 0.1
ANGULAR: $\pm 2^\circ$

	NAME	SIGNATURE	DATE	FINISH:
DRAWN	CEP		DATE	
CHK'D				MATERIAL:
APPV'D				MINIPACK
MFG				WEIGHT:
Q.A				

TITLE: Hydraulic power pack - Minipack HPM-220-xxx-x-S-N-N-08P-NNN	
DWG NO.	A4
HPM-220-xxx-x-S-N-N-08P-NNN	ISSUE 00
SCALE:1:8 DO NOT SCALE DRAWING	SHEET 1 OF 1
Dimensions in mm	